



## table of contents

---

### GENERAL DESCRIPTION

Introduction

General Design

### OPERATIONAL TECHNIQUES

Zeroing a Dosimeter

Dosimeter "Kick" Compensation

Unsticking the Fiber of a Dosimeter

Test for Proper Dosimeter Switch Operation

### ASSEMBLY INSTRUCTIONS

### PARTS LIST

## **list of illustrations**

---

- |                 |   |
|-----------------|---|
| Figure 30-1     | Self-Reading Dosimeter<br>Charger Hole Plan |
| Figure 30-2, 2A | Self-Reading Dosimeter<br>Charger           |
| Figure 30-3     | Self-Reading Dosimeter<br>Charger Schematic |

**SELF-READING DOSIMETER CHARGER (AC MODEL)  
ASSEMBLY AND OPERATING INSTRUCTIONS**

Operating and assembly instructions are for a special-purpose dosimeter charger that FEMA's Emergency Management Test Facility designed. State shops are to use this AC-operated charger as a standard piece of test equipment. It provides for the rapid, accurate charging of quartz-fiber, self-reading dosimeters. Using this charger should save considerable time in processing large quantities of dosimeters.

FEMA furnished State M&C Shops with unassembled kits. Kits include all components listed in Table 30-1. FEMA has also furnished item AL-1, Box, Aluminum, Bud #AC-430 pre-drilled, according to Figure 30-1.

The instructions are designed to enable State M&C Shops to construct additional chargers, if desired. Cost of constructing additional charger units is allowable under the States' Radiological Equipment Inspection, Maintenance, and Calibration contract.

AC Charger**SELF-READING DOSIMETER CHARGER (AC MODEL)  
ASSEMBLY AND OPERATING INSTRUCTIONS**

These instructions describe assembly and operation of a dosimeter charger developed by the Emergency Management System Test Facility for rapid charging and testing of self-reading, quartz-fiber dosimeters under shop or laboratory conditions. State M&C Shops are still responsible for testing each dosimeter that is with a kit of instruments on the respective charger to ensure their compatibility.

**General Design**

The standard 115 VAC source provides the charger's input power, instead of a battery. The DC-output voltage to the pedestal is adjusted by a potentiometer and provides charging voltages from 0 to 300 VDC, ensuring that the fiber can be positioned at any point on the scale.

Charger components are different from those of the standard CD V-750—the charging assembly is on the right side of the case and the voltage adjustment is on the left. This enables operators to use their right hands to apply force to the dosimeter charging switch, making it easier for right-handed people.

A discharge switch is below the voltage adjustment knob and is easily operated with the left thumb without moving the left hand from the voltage adjustment knob. The primary purpose of this switch is to remove the charge remaining on the charging pin of the dosimeter after the dosimeter has been zeroed. If this charge is not removed from the pin of the dosimeter when zeroing, it will leak off with time causing an up-scale shift of the fiber. This shift might then be concluded to be either dosimeter "leakage" or a radiation dose; both of which would be untrue. This effect is more noticeable on the CD V-138, low-capacity (0-200 mR)-type dosimeters. Discharging the dosimeter pin after zeroing is attempted in the CD V-750 charger units by critical switch arrangements.

AC Charger

However, the degree of pin discharge is relative to the operator in that it also involves the speed with which the dosimeter is removed from the pedestal after zeroing. That is, the faster a dosimeter is removed from the pedestal, the less the pin is discharged. This effect is commonly called charger "kick"—it is observed when a low-capacity dosimeter is zeroed or charged on a CD V-750 charger and then the dosimeter fiber is observed with some external light source and found to have moved up scale as a result of the discharge of the pin. Compensating for the "kick" effect with a CD V-750 charger is tedious because of the pedestal and dosimeter switches and output impedance of the CD V-750 charger, as well as the random speed of the operator. With this AC-powered charger, the dosimeter pin is completely discharged when the discharge button is depressed and the degree of "kick" can accurately be determined and easily compensated for during the charging operation.

A 12.5 V lamp operated 6.3 VAC is used as the source of illumination. Reasons for operating the lamp at this voltage are:

- Operating life of the lamp increases.
- Glare of the lamp decreases, producing a soft light (predominately in the red spectrum) that makes the image of the quartz fiber look more opaque but provides adequate light to read the scale.

The pedestal center charging contact diameter of the specially modified charging pedestal assembly has been increased to 3/32 inch to ensure a good contact with the charging pin of the dosimeter and to reduce the possibility of bending the pin because of misalignment. This assembly also provides a maximum force of 7.75 pounds on the dosimeter charging pin. This ensures adequate force to operate almost all bellows or diaphragm dosimeter charging switches.

The standard switching system used in the CD V-750 has been replaced by an "ON-OFF" switch for both the light and charging voltages. The light and charging voltages are applied to the pedestal whenever the potentiometer is in the "ON" position.

### AC Charger

The charger has binding posts added so that you can use a high-impedance voltmeter to measure the output voltage of the charger. For this measurement, you may use the standard VTVM with a high-impedance probe currently in the maintenance system. This will enable you to determine the voltage linearity of the dosimeter electrometer over its on-scale voltage range; however, precise calibration of the VTVM is necessary.

### Operational Techniques

#### ZEROING A DOSIMETER

1. Turn the charger on by pulling up the voltage adjust knob.
2. Place a dosimeter on the pedestal and depress.
3. Turn the voltage adjust knob until the fiber is on zero.
4. Release the pressure on the dosimeter, but leave the dosimeter on the pedestal.
5. Depress the discharge button and **hold**.
6. Lift the dosimeter off the pedestal.
7. Release the discharge button.

#### DOSIMETER "KICK" COMPENSATION

1. Perform Steps 1-5 under "Zeroing a Dosimeter."
2. During Step 5, observe the degree of "kick" in terms of scale divisions.
3. Release the discharge button and depress the dosimeter on the pedestal. Set the fiber the observed "kick" distance below zero.
4. Release the pressure on the dosimeter. Depress the discharge button and **hold**. The fiber should "kick" to zero. If not, repeat Steps 2-6 under "Dosimeter 'Kick' Compensation."
5. Remove the dosimeter from the pedestal.
6. Release the discharge button.

**UNSTICKING THE FIBER OF A DOSIMETER**

1. Place the dosimeter on the charger pedestal and depress.
2. Turn the voltage adjust to provide the maximum charger output voltage.
3. **Do not** depress the discharge button.
4. Remove the dosimeter from the pedestal and, by holding one end of the dosimeter firmly to the bench top, raise the other end and then release, letting the dosimeter "snap" against the bench.
5. Charge the dosimeter as outlined in "Zeroing a Dosimeter," Steps 1-7. If there is still no fiber, repeat "Unsticking the Fiber of a Dosimeter," Steps 1-4, several times.

**TEST FOR PROPER DOSIMETER SWITCH OPERATION**

1. Charge dosimeter as outlined in "Zeroing a Dosimeter," Steps 1-5.
2. During Step 5, observe the fiber for up-scale drift. If the fiber drifts up scale, remove the dosimeter from the charger and pull out on the dosimeter pin with pliers.
3. Retest the dosimeter.

**Assembly Instructions**

1. Remove all components from the kit and compare them with the "Parts List for Special Self-Reading Dosimeter Charger," Table 30-1.
2. Refer to Figure 30-1. Locate and drill the appropriate size holes in the box.
3. Refer to Figures 30-1. and 30-2 for hole designation and proper orientation of components.
4. Install a four-lug terminal strip (TB-16) using holes a-7 and a-8 with 6-32 x 1/4 bolts, #6 lockwashers, and 6-32 nuts.
5. Install a four-lug terminal strip (TB-17) using holes a-5 and a-6 with 6-32 x 1/4 bolts, #6 lockwashers, and 6-32 nuts.
6. Install a two-lug terminal strip (TB-15) using hole a-9 with 6-32 x 1/4 bolts, #6 lockwashers, and 6-32 nuts.
7. Install the momentary push-button switch (S-5) in hole e.
8. Install the red binding post (RP-6) in hole b-1 and the black binding post (BP-7) in hole b-2.



10. Locate the 5 M potentiometer (P-4). **CAUTION: Be sure the potentiometer shaft is pushed in before proceeding.** See Figure 30-2. Measure and mark 3/8 inch upward along the shaft from the top of the threaded mounting collar. Cut off shaft with hacksaw and smooth any burrs with file. Bend the indexing tabs of the potentiometer flush to obtain flat mounting.
  11. Install the potentiometer (P-4) in hole c.
  12. Install the modified charging pedestal assembly (PE-13) in hole d.
  13. Locate the transformer (TF-2) and prepare the leads as follows:
    - Cut the red-yellow wire at 1/4 inch (not used).
    - Cut the two red and two black leads at 6 inches.
    - Cut the two yellow leads at 3 inches.
- Note: All insulated wires will be stripped and tinned 3/8 inch where they are to be soldered.
14. Install the transformer (TF-2) using holes a-10 and a-11 with 6-32 x 1/4 bolts, #6 lockwashers, and 6-32 nuts.
  15. Twist the red transformer leads together and solder one lead in the bottom hole of terminal 1 of (TB-17). Solder the other lead in the bottom hole of terminal 2 of (TB-17).
  16. Solder one yellow transformer lead to the ground lug of the pedestal assembly (PE-13).
  17. Solder the other yellow transformer lead to the center of the light bulb socket of the pedestal assembly (PE-13).
  18. Twist black transformer leads and solder one lead in the bottom hole of terminal 1 of (TB-15). Solder the other lead to terminal 4 of the potentiometer/switch (P-4).
  19. Attach the black 2-inch lead coming from the pedestal assembly to the red binding post (BP-6).
  20. Prepare a 3 1/2-inch length of black hookup wire. Solder one end to the red binding post (BP-6) and solder the other end to terminal 2 of the momentary push-button switch (S-5).
  21. Prepare a 1 1/2-inch and a 4 1/2-inch length of hookup wire. Solder one end of each wire to the black binding post (BP-7). Solder the remaining end of the 1 1/2-inch lead to terminal 3 of potentiometer/switch (P-4). Fasten the remaining end of the 4 1/2-inch lead in the bottom hole of terminal 2 of (TB-15).
  22. Prepare a 2 1/2-inch length of hookup wire. Solder one end to terminal 2 of potentiometer/switch (P-4). Solder the remaining end to terminal 3 of push-button switch (S-5).

AC Charger

23. Prepare a 2-inch length of hookup wire. Solder one end to terminal 1 of push-button switch (S-5). Solder the remaining end in the bottom hole of terminal 2 of (TB-15).
24. Prepare a 4-inch length of hookup wire. Solder one end to terminal 1 of potentiometer/switch (P-4). Solder the other end in the bottom hole of terminal 4 of (TB-17).
25. Bend the leads of the resistor (R-12) and fasten them between the terminals 3 and 4 of (TB-17).
26. Lace a 3-inch length of base buss wire using the bottom holes of TB-16 from terminal 1 to terminal 3 to terminal 4 and to ground terminal 5. Solder all connections.
27. Prepare a 3-inch length of hookup wire. Solder one end in the bottom hole of terminal 2 of (TB-16). Solder the other end in the bottom hole of terminal 3 of (TB-17).
28. Solder the anode end of diode D-24 to terminal 1 of (TB-16). Attach the other end to terminal 1 of (TB-17).
29. Solder the anode end of diode D-25 to terminal 1 of (TB-17). Attach the other end to terminal 2 of (TB-16).
30. Solder the cathode end of diode D-26 to terminal 2 of (TB-16). Attach the other end to terminal 2 of (TB-17).
31. Solder the cathode end of diode D-27 to terminal 2 of (TB-17). Attach the other end to terminal 3 of (TB-16).
32. Solder the black band end of capacitor C-11 to terminal 3 of (TB-16). Solder the other end to terminal 3 of (TB-17).
33. Solder the black band end of capacitor C-10 to terminal 4 of (TB-16). Solder the other end to terminal 4 of (TB-17).
34. Cut three inches of outer insulation from both ends of the AC-power cord (PC-8).
35. Prepare one end of the power cord by cutting the white and green leads to one inch. Feed this end through grommet (GR-14). Solder the green lead to terminal 2 of (TB-15). Solder the white lead to terminal 1 of (TB-15). Solder the black lead to terminal 5 of (P-4).
36. Strip 2 inches of insulation from each lead of the other end of the power cord. Do not tin but twist strands tightly. Feed this end of the power cord into plug (PL-9) and tighten clamp over outer insulation. Loosen terminal screws of plug out to maximum. Wrap green wire around green screw and tighten screw. Wrap white wire around white screw and tighten. Wrap black wire around gold screw and tighten. Cut off excess wire and install safety plate.
37. Install the lamp (LA-3) in the pedestal socket.

AC Charger

38. Install the knob (K-23) on the potentiometer shaft and tighten set screw.
39. Install the four rubber bumpers (RB-22) in each corner of box at holes a-1 through a-4.

**TABLE 30-1  
PARTS LIST**

Item Number	Nomenclature	Amount Each
AL-1	Box--Aluminum, Bud #AC-430	1
TF-2	Transformer--Power, Thordarson #22R39	1
LA-3	Lamp--12.5V, GE-428	1
P-4	Potentiometer switch--5 meg. Mallory #PP56L	1
S-5	Switch--SPDT, momentary push button, Grayhill #46-102B	1
BP-6	Binding Post--Red, E.F. Johnson #111-300	1
BP-7	Binding Post--Black, E.F. Johnson #111-300	1
PC-8	Power Cord--3 wire, 8 length, Belden #18130	1
PL-9	Plug--Grounded type, AC	1
C-10	Capacitor--1 Fd, 600V	1
C-11	Capacitor--.01 Fd, 600V	1
R-12	Resistor--1.5M 1/2W	1
PE-12	Charging Pedestal Assembly (modified specially for this device)--Sort Code 21692	1
GR-14	Grommet--Smith #2175	1
TB-15	Terminal Strip--2 lug, H.H. Smith #862	1
TB-16/17	Terminal Strip--4 lug, C.J. #54	2
B-18	Bolts--6-32 x 1/4", binder head, plated	7
LW-19	Lockwashers #6--Internal Star, plated	7
N-20	Nuts--6-32, plated	7
W-21	Wire--36 inches, black	1
RB-22	Rubber Bumpers w/screw--Smith #2198	4
K-23	Knob--Smith #2240	1
D-24/27	Diode--1N2070A, Sort Code 22201	4
W-28	Wire--solid, #22, bare, 6"	1



AC Charger

Figure 30-2  
Self-Reading Dosimeter Charger

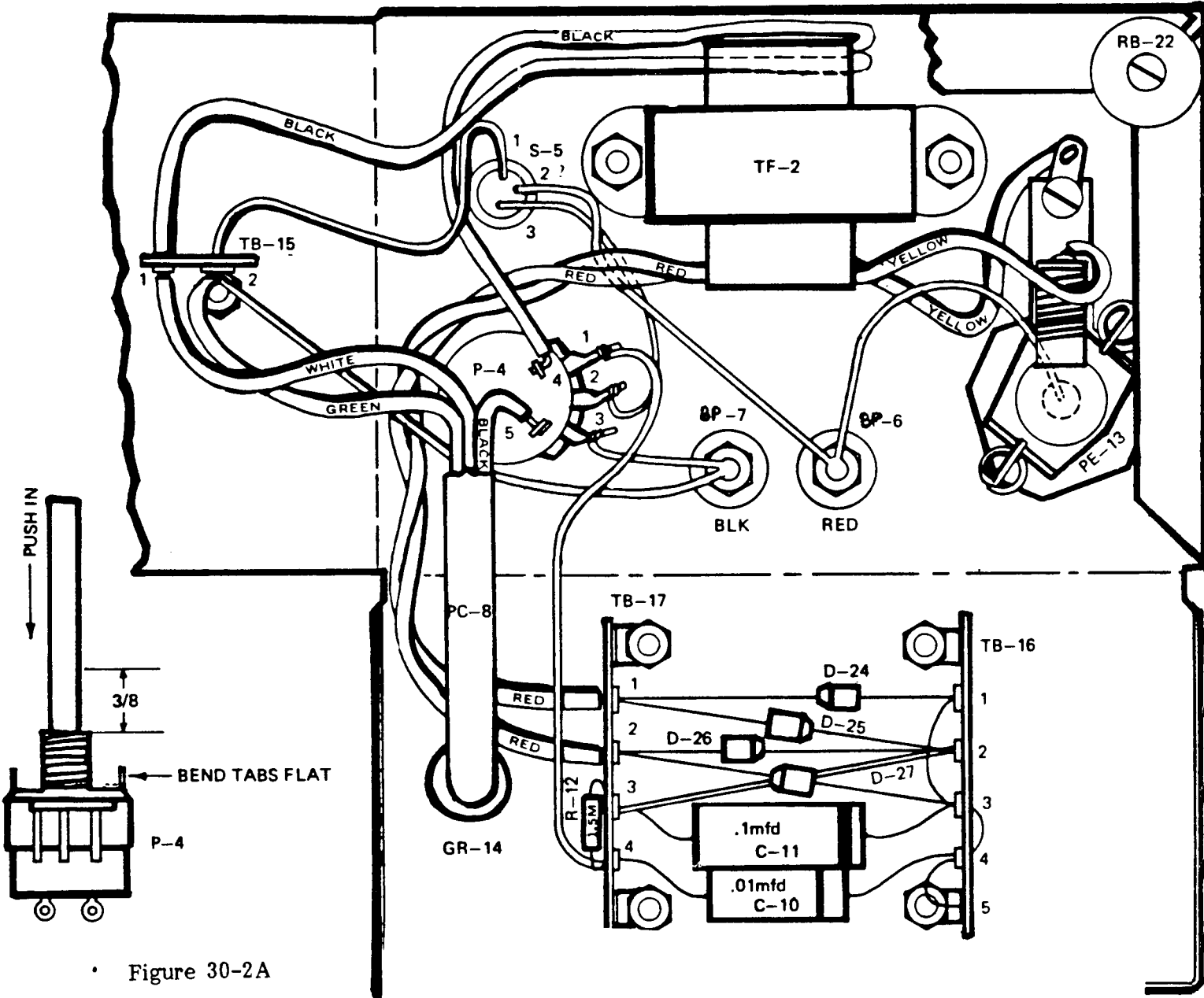

• Figure 30-2A

AC Charger

Figure 30-3  
Self-Reading Dosimeter Charger Schematic

